

Instructions for Use

Absorbance 96 Automate

Valid for REF Number DE MAA 001

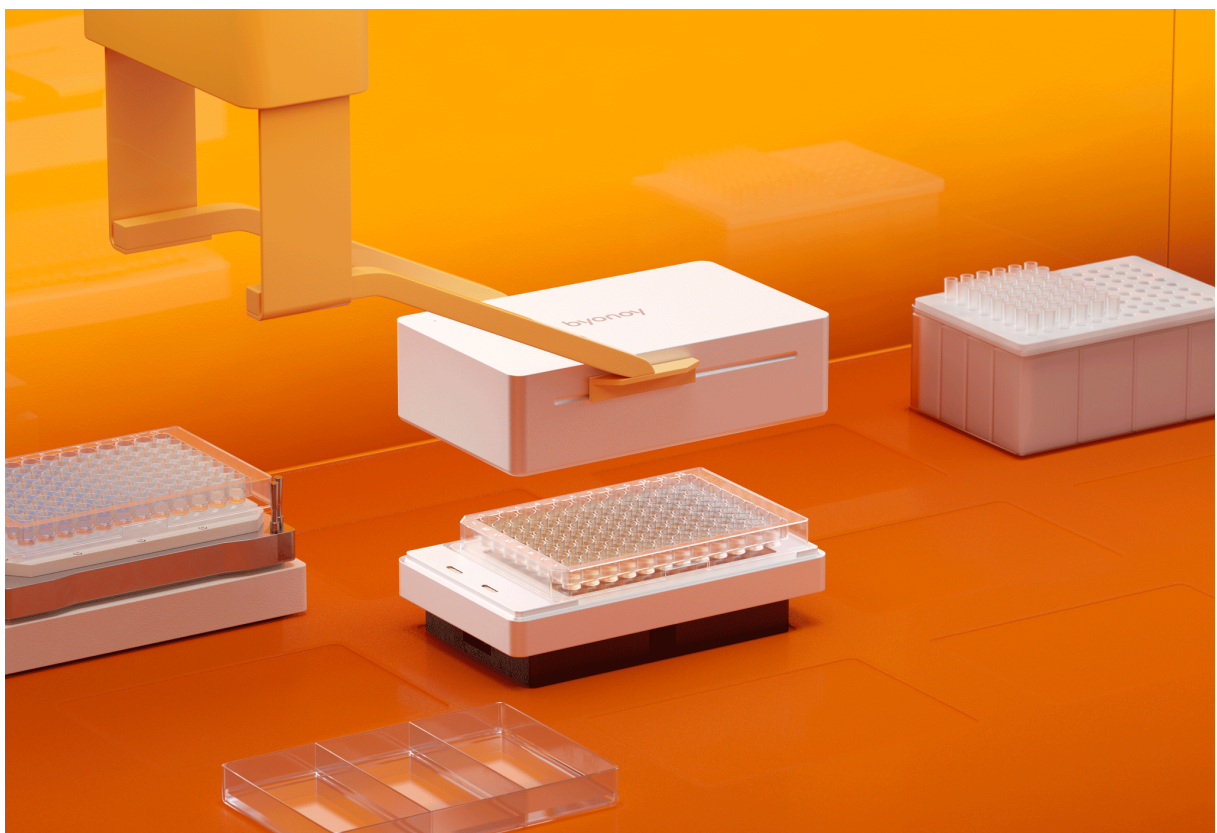

Instructions for Use

Absorbance 96 Automate

Version 1.1 (20/02/2024)

©Copyright 2024 by Byonoy GmbH. All rights reserved.

Manufacturer: Byonoy GmbH
Schützenstraße 21
22761 Hamburg, Germany

00 49 40 5379 866 00
service@byonoy.com
www.byonoy.com

Dear customer,

We are delighted that you have chosen Absorbance 96 Automate. To take full advantage of the reader's performance and to enjoy your reader for many years, please read these instructions for use carefully before installation and commissioning. Operate the reader in accordance with these instructions. The operating-safety and function of the reader can only be guaranteed if both the general safety regulations and accident prevention regulations of the legislator as well as the safety instructions in this manual are observed.



Ensure that the manual is always accessible and is read and understood by all persons operating the reader.

This user manual may only be used according to its intended purpose. It may not be reproduced, changed, or translated in another language without the prior written consent of Byonoy GmbH.

This document is subject to technical changes and updates.

TABLE OF CONTENTS









1	General information.....	1
2	Overview of Absorbance 96 Automate.....	3
2.1	Scope of application.....	3
2.2	Measurement method.....	3
2.3	Absorbance 96 Automate System.....	4
2.4	Consumables.....	5
3	Preparing the product for use.....	6
3.1	Unpacking, storage, and transport.....	6
3.2	Supplied materials.....	6
3.3	Working environment.....	7
3.4	Installation.....	7
4	Operation.....	10
4.1	App installation procedure and updates.....	10
4.2	Computer connection.....	10
4.3	Workflow.....	10
5	Signals and troubleshooting.....	12
5.1	Signal lights.....	12
5.2	Troubleshooting.....	12
6	Maintenance and cleaning.....	13
6.1	Maintenance.....	13
6.2	Cleaning.....	14
6.3	Technical support.....	15
6.4	Repairs.....	15
7	Technical specifications.....	16
8	Guarantee.....	18
9	Declaration of Conformity.....	19

1 General information

Important: Follow the instructions for use

Any commissioning or handling of the reader requires precise knowledge and notice of this manual. The device is intended for the described use only.

In this manual and on the label of the reader particularly important remarks are labeled as followed:

Symbol	Description
	Caution: Caution indicates a potentially hazardous situation, which, if not avoided, could result in minor or moderate injury.
	Information: This is a piece of information indicating certain properties that must be observed.
	Certification mark that indicates conformity with health, safety, and environmental protection standards for products sold within the European Economic Area.
	Disposal of used electrical and electronic equipment
	Manufacturer
	Serial number
	Consult instruction for use (user manual)
	Catalogue number

Liability for function and damage

Liability for the function of the device shall, in any case, pass to the owner or operator if the device is improperly maintained, repaired, or modified by persons who do not belong to the authorized service personnel, or if it is handled in a way that does not comply with its intended use. The service and operation of the product must be in accordance with this manual. Byonoy shall not be liable for damages resulting from non-observance of the information

above. Warranty and liability conditions of the terms of sale and delivery of Byonoy are not extended by the information above.

Disposal of used electrical and electronic equipment



The symbol on the product or its packaging indicates that this product is not to be treated as normal household waste. It must be disposed of at a collection point for the recycling of electrical and electronic equipment. By contributing to the correct disposal of this product, you protect the environment and the health of your fellow human beings. Recycling helps to reduce the consumption of raw materials. For further information on how to recycle this product, please contact your local authority or municipal waste disposal centres.

Recycling of the product may also be carried out by the manufacturer. Please contact the service department.

Working with biological and harmful material

Absorbance 96 Automate is not to be used for the measurement of biohazardous substances.

Always observe the manufacturer's hazard information pertaining to the substances to be measured.

The reader does not produce any toxic or harmful gases or substances. During the measurement, make sure that there are no toxic or harmful substances in the microtiter plate.

2 Overview of Absorbance 96 Automate

2.1 Scope of application

Absorbance 96 Automate is an optical laboratory instrument for measuring the absorbance (optical density) of biological or non-biological samples in ANSI/SBS-standard 96-well microtiter plates in accordance with the specifications described in the user manual. Absorbance 96 Automate is an on-deck microplate reader module designed for easy integration into various liquid handling or robotic systems.

Absorbance 96 Automate is intended for research and other non-in-vitro-diagnostic analyses only. It is to be operated by trained laboratory personnel and is intended for professional use.

2.2 Measurement method

Absorbance 96 Automate is designed to carry out sensitive absorbance measurements. It measures the optical density (OD) of samples at defined wavelengths.

Absorption

Absorption refers to the amount of light absorbed by a medium. Absorption reduces transmission. Transmission is the ratio of incident to transmitted light. Accordingly, the degree of transmission is calculated as follows

$$T = (I/I_0)$$

where I is transmitted light and I_0 is incident light.

Optical Density

Optical density is a measure of the attenuation of light radiation after it has passed through a medium. Optical density is the logarithmic quantity that describes the reciprocal of the transmittance T :

$$OD = \log(I_0/I)$$

where I is the transmitted light and I_0 is the incident light.

Optical density is the absorbance of the sample plus other attenuating effects such as scattered light due to turbidity. It is therefore necessary to avoid scattered light to measure absorbance correctly.

If no other attenuating effects are present, absorbance = optical density.

2.3 Absorbance 96 Automate System

Absorbance 96 Automate Reader

Absorbance 96 Automate is an absorbance-based measuring device, i. e. a measuring instrument, with which the absorbance values of a 96-well microtiter plate can be read, recorded, and provided for further processing. Absorbance 96 Automate is a solid-state microplate reader and has 96 detection units, allowing measurement without a scanning mechanism.

The Absorbance 96 Automate is primarily designed to be integrated on-deck of various liquid handling systems and other robotic systems.

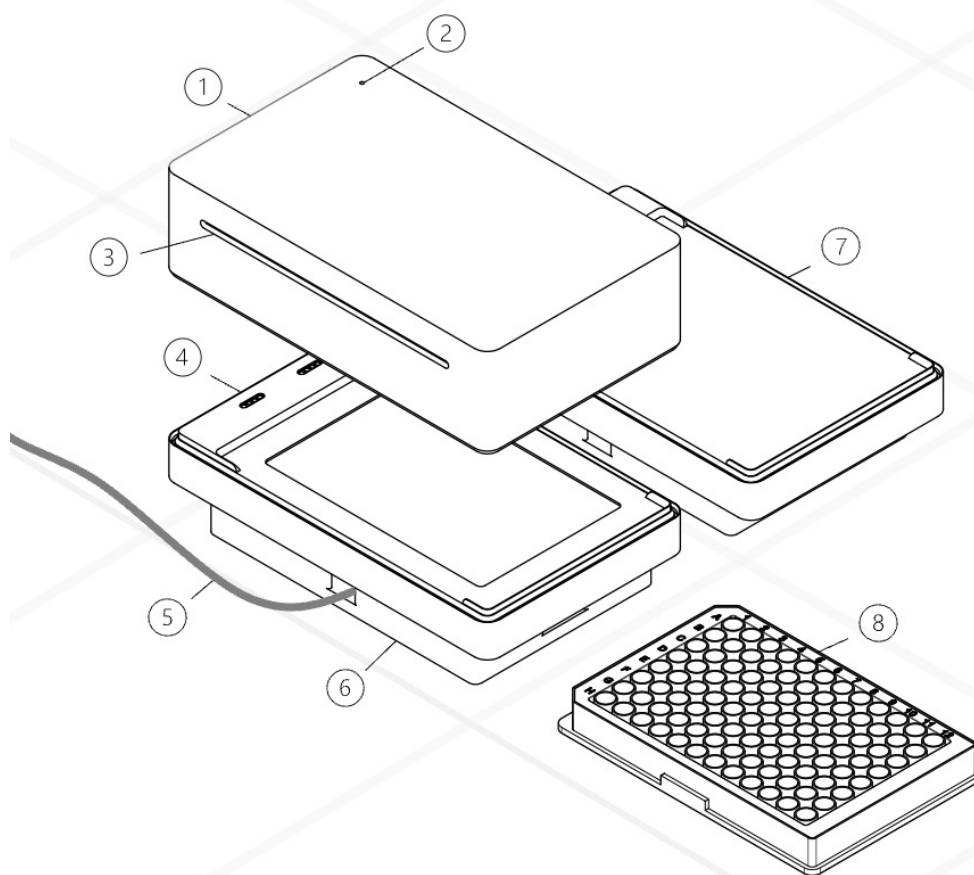

Figure 1. Visual representation of the product from the front, top. 1. Illumination unit, 2. Signal light, 3. Groove for the gripper, 4. Detection unit, 5. USB-C cable, 6. SBS adapter, 7. Parking position, 8. Microplate.

In the illumination unit of the reader, there are up to 6 LED light sources with different wavelengths and up to 6 interference filters. The signal light positioned at the top of the illumination unit displays the current status of the reader, including its connection status, initialization progress, measurement status, and any errors that may have occurred.

In the detection unit of the reader, 96 photodiodes collect the light passing through the microtiter plate. The illumination unit and the detection unit are connected via spring contacts.

The microtiter plate is loaded onto the reader using the gripper of the liquid handler.

On the bottom of the detection unit there is a USB-C port for connecting the reader to a computer via the included USB-C cable.

Power consumption

The power consumption of Absorbance 96 Automate is very low. It is operated by a USB-C cable and the total power consumption is generally less than 2.5 watts.

Absorbance 96 App

The reader is controlled via the Absorbance 96 App. The operation of the app is described in detail in a separate user manual.

2.4 Consumables

With Absorbance 96 Automate, ANSI/SBS Standard 96-well microtiter plates can be used. Only certain microtiter plate types can be used with Absorbance 96 Automate (see chapter 7).

When using microtiter plates, always check the specifications of the microtiter plate manufacturer. Not all microtiter plates of a particular manufacturer are the same in design, materials, or configuration. The temperature stability within the microtiter plate can depend on the type of microtiter plate used.

3 Preparing the product for use

3.1 Unpacking, storage, and transport

Unpacking

The device is packed in a specially designed cardboard box. Keep the packaging material. If the device must be returned for repair, the original packaging material must be used.

Storage and protection during the intervals of normal use

-  **Protect the device from moisture and dust during prolonged storage.**

-  **Do not store the device next to heat sources and protect it from direct sunlight.**

The temperature for storage should be within the recommended temperature range (see chapter 7).

Transportation

Before transportation, unplug the reader and ensure there is no microtiter plate inside the device. Depending on the transport distance, use the original packaging material. Make sure that the new location meets the requirements described in chapter 7.

-  **To avoid spillage and contamination, make sure that there is no microtiter plate inside the reader before transport.**

3.2 Supplied materials

When unpacking the device, please check that the following components are present:

- Absorbance 96 Automate
 - Illumination unit
 - Detection unit (with SBS adapter)
 - Parking position (with SBS adapter)
- USB-C cable
- Hex key
- Microfiber cloth
- Information card with the download link
- Calibration certificate

3.3 Working environment

The Absorbance 96 Automate is designed to be integrated on-deck into liquid handling and other robotic systems.

The following information must be observed. Ignoring them may lead to measurement errors and a reduction in the expected lifetime or damage to the device:

- ① **Do not operate the device near heat sources or under direct sunlight.**
- ① **The ambient temperature and the humidity should be within the recommended range (see chapter 7).**

3.4 Installation

Before commissioning Absorbance 96 Automate, you should carefully read and understand the entire manual to familiarize yourself with the system.

Absorbance 96 Automate is controlled via the Absorbance 96 App, including the analysis of measurement data. The functions of the app are detailed in a separate user manual.

Commissioning Absorbance 96 Automate entails three integration steps:

1. Placement on-deck
2. Preparing the liquid handler
3. Integrating with the software

Each of these steps are explained below in further detail.

Placement on-deck

Prior to setting up the reader, connect the detection unit to the USB-C cable as depicted in Figure 2. Remove the SBS adapter by loosening the pair of screws. Insert the USB-C cable and route it in the appropriate direction based on your deck's layout. Replace the screws to reattach the SBS adapter.

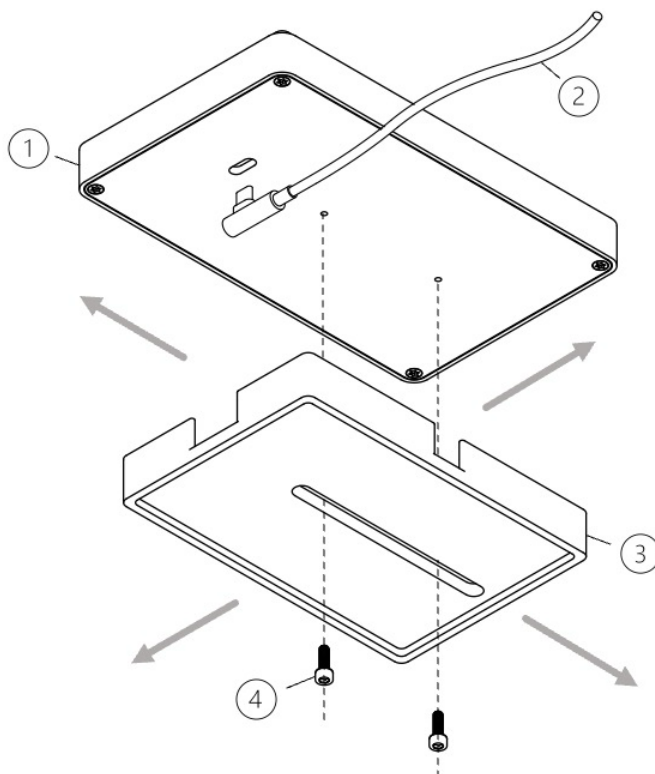

Figure 2. Installation of the USB-C cable. 1. Detection unit, 2. USB-C cable, 3. SBS adapter, 4. Screws.

Position the detection unit and the parking position on any available SBS deck position of the liquid handling system. Route the USB-C cable toward a computer or compatible device and connect it. Place the illumination unit on top of the detection unit.

As the detection unit and the parking position exceed the dimensions of the SBS standard, it may be beneficial to shift the SBS adapter towards the device's periphery, as illustrated in Figure 3.

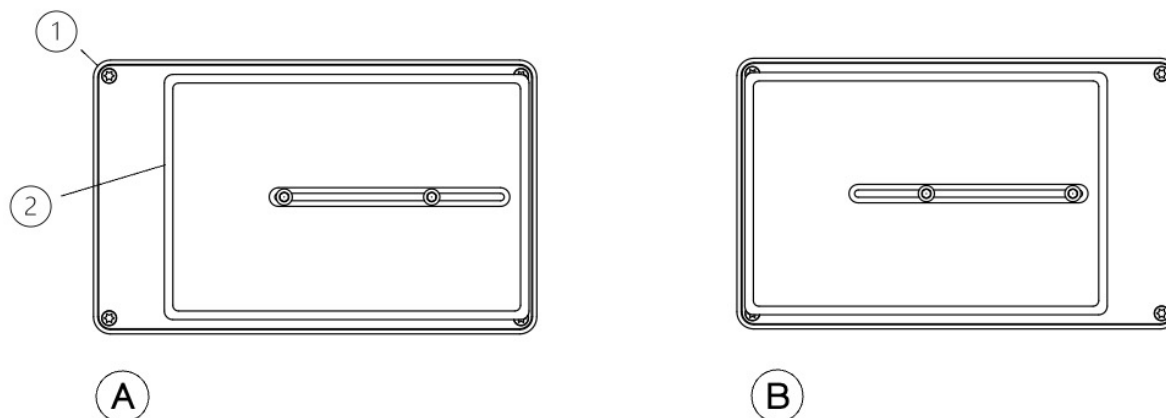

Figure 3. Possible SBS positions. Bottom view. 1. Detection unit or parking position. 2. SBS adapter.

Provided that an SBS outlay is present, the detection unit may be simply placed on-deck: no further hardware is required to affix the reader.

- ① **Consult the specific requirements of your liquid handling system for instructions on affixing hardware on-deck**

Preparing the liquid handling system

Once Absorbance 96 Automate has been installed on-deck, the gripper of the liquid handling system must be taught to interact with it.

- ① **Consult the manual of your liquid handling system for teaching instructions.**
- ① **Labware descriptions may already be available for your liquid handling system. Contact us for more information at service@byonoy.com.**

Integrating with the software

The Absorbance 96 Automate is controlled via the Absorbance 96 App. The Absorbance 96 App can connect via SiLA2 to enable remote execution of commands including loading a protocol, performing a measurement, and exporting the results as a .csv file. Specific Instructions for Use for the SiLA2 interface can be downloaded from the following webpage: s.byonoy.com/abs96auto.

- ① **System-specific drivers may already be available for your liquid handling system. Contact your liquid handling system provider for more information or contact us at service@byonoy.com.**

4 Operation

The functions of the Absorbance 96 Automate are controlled via the Absorbance 96 App, including the analysis of measurement data. The functions of the app are detailed in a separate user manual.

4.1 App installation procedure and updates

The Absorbance 96 App is compatible with Windows and MacOS operating systems (see chapter 7).

To install the Absorbance 96 App, visit the following webpage: s.byonoy.com/abs96. Download the latest version of the App for your operating system and follow the steps in the Setup Wizard to complete the installation.

-  **To install the proper drivers and software on the computer, the user must have administrator rights or obtain such permissions.**

4.2 Computer connection

Absorbance 96 Automate requires a connection to the computer for power supply, reader control, and data transfer. Absorbance 96 Automate starts automatically when connected to a computer via the USB-C cable and the software automatically establishes a connection.



Always use the included Micro-USB cable for the connection to your computer.

-  **Connect the reader directly to your computer and do not use an external USB hub.**

-  **The device may only be operated at a USB port USB 2/USB 3 with 5 VDC and a maximum of 3 A of a certificated computer (with certification mark of an approved testing laboratory). Use an adapter cable on USB 3.1 with type C plug connection, which ensures the profile 1: 5 V@2.0 A.**

When Absorbance 96 Automate is switched on, the signal light on the top of the reader lights up. Each time the reader is switched on, an internal self-test is performed to ensure there are no malfunctions.

4.3 Workflow

Microtiter plate loading

Absorbance 96 Automate is operated using the gripper of the liquid handling or robotic system. To load a microtiter plate into the reader the gripper performs three steps, which are illustrated in Figure 4.

1. Moving the illumination unit to the parking position.
2. Moving the microtiter plate to the detection unit.
3. Moving the illumination unit back to the detection unit.

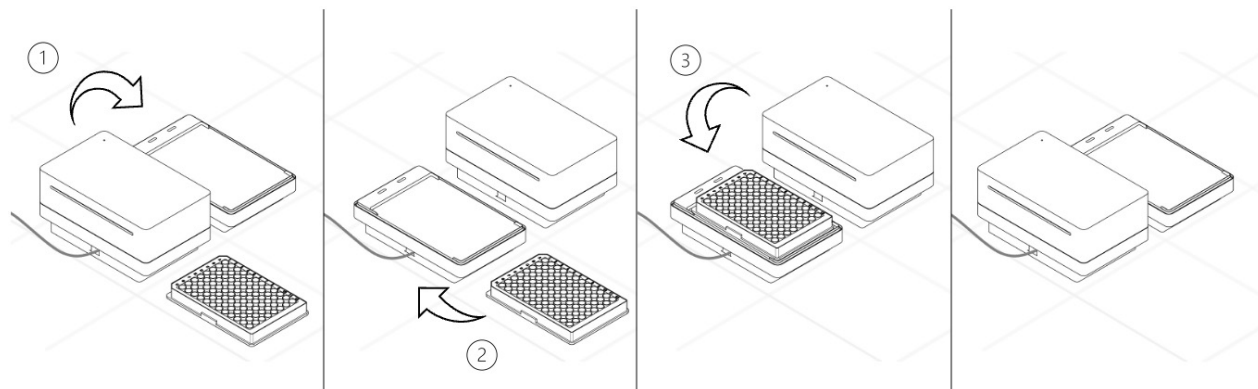

Figure 4. Three steps to load the microplate into the reader utilizing the gripper.

Assay readout

Once all settings have been completed, the measurement can be started. The app will automatically guide the user through the readout process.

To guarantee a correct measurement result, pay attention to the indications in the Absorbance 96 App and heed the following information:

- i** Shocks to Absorbance 96 Automate or the microtiter plate can cause an unwanted signal. Therefore, neither Absorbance 96 Automate nor the microtiter plate should be touched during measurement.

After a successful measurement, the results section will open automatically in the app.

Removing microtiter plate

The microtiter plate must be removed from the Absorbance 96 Automate after the readout. To do this, reverse the steps for the loading procedure.

- i** Make sure not to store a microtiter plate filled with reagents in the device, as evaporating gases can damage the device and especially the filters.

5 Signals and troubleshooting

5.1 Signal lights

Table 1. Explanation of the signal lights

Activity of the signal light	Meaning
White, pulsating	Self-test after connection to power.
White, continuous	Device is on and ready for readout.
Colored, continuous	Initialization/measurement in progress. The color of the signal light indicates the wavelength of the filter.
Yellow, pulsating	A microtiter plate is inside the reader.
Red, blinking	Error

5.2 Troubleshooting

If there is an error, the signal light will blink red. In this case, check the app to see which error is present.

Table 2. Error messages and solutions

Type of error	Cause	Solution
Initialization failed.	There was a microtiter plate in the slot during initialization.	Remove the plate.
	The inside of the slot is dirty.	Clean the inside of the slot according to the cleaning instructions in chapter 6.2.
	Irrecoverable hardware error.	Contact the service department.
Temperature out of specification.	The ambient temperature was too high or too low.	Make sure the ambient temperature is within the specifications.
USB Power Supply Defective (< 450mA or < 4V).	Defective USB port.	Use a different USB port on the computer or a different computer.
	Using a USB hub.	Connect the reader directly to the computer.
	Defective Micro-USB cable.	Contact the service department.
Irrecoverable hardware error.	Irrecoverable hardware error.	Contact the service department.

6 Maintenance and cleaning

6.1 Maintenance

Absorbance 96 Automate is maintenance-free. Each time the reader is switched on, an internal self-test is carried out to ensure there are no malfunctions.

There are no parts within Absorbance 96 Automate that can be serviced by the customer. It is only necessary to ensure that the device is kept clean.

The accuracy, linearity and reproducibility of the device can be checked with a reference plate. Byonoy recommends the reference plate from Hellma GmbH (item code 666-R013), for which the following steps are described.

Accuracy

1. Measure the plate at the desired wavelength. Ensure that there is no dust or other contamination on the reference plate.
2. Compare results taking the measurement uncertainty and specifications of the reader into account and use the following formula:
$$OD_{RP} - MU - AS \leq OD_{RES} \leq OD_{RP} + MU + AS$$

OD_{RP} : Optical density of the reference plate at the desired wavelength. This value is found on the calibration certificate from the manufacturer of the reference plate.

MU : Measurement uncertainty of the reference plate. This value is found on the calibration certificate from the manufacturer of the reference plate.

AS : Accuracy specification of the reader at measured optical density. This value is shown in chapter 7.

OD_{RES} : The optical density measured by the reader at the desired wavelength.

Example:

OD_{RP} : 1.554

MU : ± 0.0079

AS : $\leq 1\% + 0.010$ OD from 0.0–2.0 OD

OD_{RES} : 1.573

$$(1) \quad 1.554 - 0.0079 - (1.554 \cdot 0.01 + 0.010) \leq OD_{RES} \leq 1.554 + 0.0079 + (1.554 \cdot 0.01 + 0.010)$$

$$(2) \quad 1.52056 \leq OD_{RES} \leq 1.58744$$

The measured optical density of the reader lies within the calculated range.

3. Rotate the reference plate by 180 degrees and repeat steps 1 and 2.
4. If all Results (OD_{RES}) are within the range, the accuracy of the device has been verified.

Linearity

With the Hellma reference plate, you can check the accuracy at 6 different OD points. If the accuracy for all these points has been verified, the linearity of the reader is also verified.

Reproducibility

1. Measure the plate at the desired wavelength for at least 3 times. Ensure that there is no dust or other contamination on the reference plate.
2. Calculate the standard deviation OD_{SD} for each well.
3. Compare the measured standard deviation and specifications of the reader using the following formula:

$$OD_{SD} \leq LS$$

OD_{SD} : Calculated standard deviation for each well

LS: Linearity specification of the reader at measured optical density. This value is found in chapter 7.

In case that the results of accuracy, linearity or reproducibility are outside the range, please contact the service department.

There are no recommended intervals for performing accuracy, linearity, and reproducibility checks. The customer may refer to their own quality control requirements.



Please follow the plate manufacturer's recalibration instructions for the reference plate.

6.2 Cleaning

Cleaning the housing

The surfaces of the housing should be cleaned regularly. For this purpose, you can use e. g. a cloth, or a sponge lightly wetted in water. For heavier soiling, clean the surface of the housing with a mild soap solution diluted with water or glass cleaner and then wipe with a lightly moistened cloth or sponge to remove any residue. Do not use scouring agents.



Cleaning the shaft

Use a dry microfiber cloth or a bellows to carefully remove dust or dirt from the surface. If this is not enough, the microfiber cloth can be slightly soaked with 80 % ethanol to carefully remove dust or contamination from the surface.

Do not allow water or other liquids to get inside the reader. If this happens, return the reader to the manufacturer for inspection.

Warnings for cleaning

When cleaning, pay attention to the following warnings. Failure to observe these warnings may result in damage to the reader. This can lead to a reduction of the service life or in measurement errors:

-  **Always avoid spraying liquid directly onto the surfaces of Absorbance 96 Automate. This is especially important for the inside of the shaft, where there are optical elements that are very sensitive and essential for the functioning of the reader.**
-  **Never clean the inside of the device interior with sharp or abrasive scourges, and do not use aggressive solvents or corrosive agents.**
-  **Biological hazard: Always wear gloves during cleaning operations that may involve contact with biological or generally hazardous materials or liquids.**

6.3 Technical support

In case of problems with the reader, please contact the manufacturer's service department or your local representative.

-  **Biological hazard: It is your responsibility to decontaminate the reader and all accessories before servicing and before returning the reader or accessories to the manufacturer.**

For decontamination of Absorbance 96 Automate, follow the government guidelines for inactivation of organisms used in biological laboratories.

6.4 Repairs

Repairs on the device may only be carried out by the manufacturer. Please contact the service department. The product warranty is voided if the device is modified by unauthorized persons, or different parts are installed.

7 Technical specifications

Table 3. Performance and technical data

Parameter	Value
Type of product	Absorbance reader
Product name	Absorbance 96 Automate
Operating Software	Absorbance 96 App
Service life	10 years at an average use of 4h/day
Housing material	Aluminium
Place for use	Laboratory
Degree of contamination	2
Temperature for storage/measurement	5–40 °C
Temperature (Transport)	-10–50 °C
Relative tolerated humidity (storage/measurement)	Max. 70 %
Measurement method	Absorbance
Measuring technique	Endpoint and Kinetic
Microplate types	96-well, flat bottom
Light source	Up to 6 LEDs
Filters	Up to 6
Detection	96 Photodiodes
Measurement range	0–4.0 OD
Resolution	0.001 OD
Accuracy*	405 nm: $\leq 1.5 \% + 0.010 \text{ OD}$ from 0.0–2.0 OD $\leq 3 \% + 0.010 \text{ OD}$ from 2.0–3.0 OD $\geq 450 \text{ nm}$: $\leq 1 \% + 0.010 \text{ OD}$ from 0.0–2.0 OD $\leq 1.5 \% + 0.010 \text{ OD}$ from 2.0–3.0 OD
Reproducibility**	$\leq 0.5 \% + 0.005 \text{ OD}$ from 0.0–2.0 OD $\leq 1 \% + 0.010 \text{ OD}$ from 2.0–3.0 OD
Linearity***	405 nm: $\leq 1.5 \%$ from 0,0–2.0 OD $\leq 3 \%$ from 2.0–3.0 OD $\geq 450 \text{ nm}$: $\leq 1 \%$ from 0,0–2.0 OD $\leq 1.5 \%$ from 2.0–3.0 OD
Connection to computer	USB 2/USB 3 with 5 VDC and max. 3 A

Dimensions reader	95.5 x 155.3 x 57 mm (W x L x H)
Dimensions SBS adapter	85.5 x 127.8 x 17 mm (W x L x H)
Power supply	5 VDC
Nominal value/Characteristic of the fuse	1 A/very fast-acting
Power input	2.5 W
Weight	Illumination unit 435 g, detection unit 355 g
System requirements (App)	Microsoft Windows: Windows 7 or above Mac OS: High Sierra 10.13 or above

*Accuracy is the maximum deviation between the determined value and the true value.

**Reproducibility is the maximum deviation between the determined values when the measurement is repeated directly.

***Linearity is the maximum deviation between the true and the determined increase of the value.

8 Guarantee

The regular warranty period of Absorbance 96 Automate is 24 months. If a defect manifests itself in your device during the warranty period, please contact the service department directly.

The reader may only be operated in technically perfect condition. In the event of defects that could endanger employees or third parties, the device may only be used again after it has been repaired by the manufacturer.

This warranty does not cover damage caused by improper use or external mechanical influences, transport damage, or unauthorized intervention in the device by unauthorized persons.

EC-Conformity Declaration



Byonoy GmbH – Schützenstraße 21 - 22761 Hamburg - Germany

The Product named below fulfills the relevant fundamental requirements of the EC directives and standards listed. In the case of unauthorized modifications to the product or an unintended use this declaration becomes invalid.

Product type

Absorbance microplate reader

Type designation

Absorbance 96 Automate

Relevant EC directives/standards

2011/65/EU; 2014/53/EU;
ETSI 301 489-1:2019

Hamburg, 28.07.2023

A handwritten signature in black ink, appearing to be 'S. Metz', written over a horizontal line.

Dr. Sebastian Metz

A handwritten signature in black ink, appearing to be 'Y. Nazirizadeh', written over a horizontal line.

Dr. Yousef Nazirizadeh